

Write your name here

Surname

Other names

Centre Number

Candidate Number

Edexcel GCE

Physics

Advanced Subsidiary

Unit 2: Physics at Work

Wednesday 5 June 2013 – Morning

Time: 1 hour 30 minutes

Paper Reference

6PH02/01R

You must have:

Ruler

Total Marks

Instructions

- Use **black** ink or ball-point pen.
- **Fill in the boxes** at the top of this page with your name, centre number and candidate number.
- Answer **all** questions.
- Answer the questions in the spaces provided
– *there may be more space than you need.*

Information

- The total mark for this paper is 80.
- The marks for **each** question are shown in brackets
– *use this as a guide as to how much time to spend on each question.*
- Questions labelled with an **asterisk** (*) are ones where the quality of your written communication will be assessed
– *you should take particular care with your spelling, punctuation and grammar, as well as the clarity of expression, on these questions.*
- The list of data, formulae and relationships is printed at the end of this booklet.
- Candidates may use a scientific calculator.

Advice

- Read each question carefully before you start to answer it.
- Keep an eye on the time.
- Try to answer every question.
- Check your answers if you have time at the end.

Turn over ►

P43322A

©2013 Pearson Education Ltd.

1/1/1/1/C2



PEARSON

SECTION A

Answer ALL questions.

For questions 1–10, in Section A, select one answer from A to D and put a cross in the box . If you change your mind, put a line through the box and then mark your new answer with a cross .

1 Which type of electromagnetic radiation is used for communicating with satellites?

- A infrared
- B microwave
- C ultraviolet
- D visible light

(Total for Question 1 = 1 mark)

2 Which of the following current – potential difference (I – V) graphs shows the correct behaviour for a filament bulb?

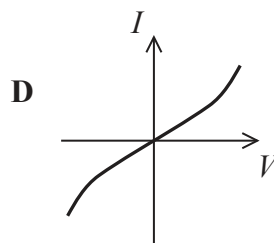
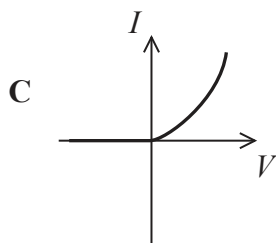
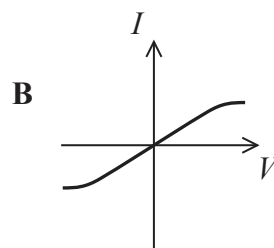
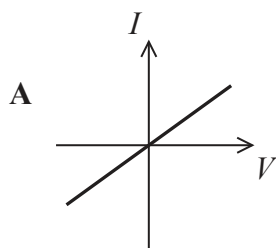

- A
- B
- C
- D

(Total for Question 2 = 1 mark)



3 A standing wave is created on a string stretched between two supports.

Which statement is always true?

- A There is a node at each end.
- B There is a node in the centre.
- C There is an antinode at each end.
- D There is an antinode in the centre.

(Total for Question 3 = 1 mark)

4 Light from a lamp passes through two polarising filters, P1 and P2, before reaching a detector. The filters initially have their planes of polarisation parallel.

The intensity of light at the detector will be greatest if

- A P1 is rotated by 45° and P2 is rotated by 315° in the same direction.
- B P1 is rotated by 90° and P2 is rotated by 270° in the same direction.
- C P1 is rotated by 45° and P2 is rotated by 270° in the same direction.
- D P1 is rotated by 90° and P2 is rotated by 315° in the same direction.

(Total for Question 4 = 1 mark)



P 4 3 3 2 2 A 0 3 2 4

5 A beam of electrons is directed towards a section of crystalline material.

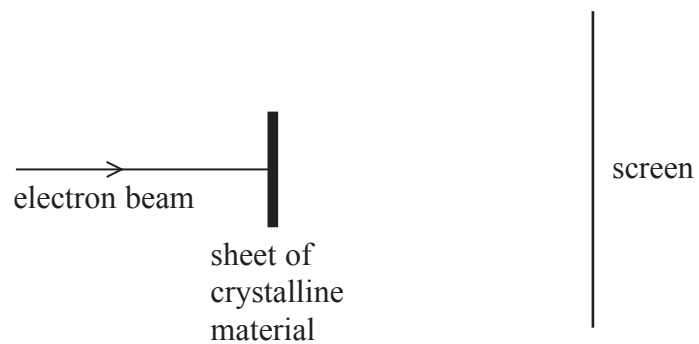

The following pattern is produced by the electrons on the screen.

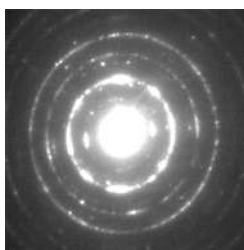

This pattern demonstrates

- A diffraction.
- B polarisation.
- C reflection.
- D refraction.

(Total for Question 5 = 1 mark)



6 The diagram shows a uniform wire XY across which a potential difference V_0 is applied.

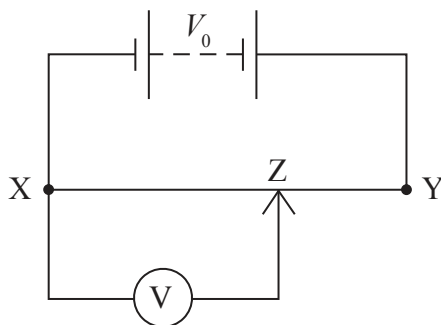

Which of the following correctly shows the output potential difference across XZ?

- A $V = \frac{XY}{XZ} V_0$
- B $V = \frac{XZ}{XY} V_0$
- C $V = \frac{XZ}{ZY} V_0$
- D $V = \frac{ZY}{XY} V_0$

(Total for Question 6 = 1 mark)

7 When a semiconductor has its temperature increased from room temperature, its resistance usually decreases because

- A the electrons are moving faster.
- B the lattice atoms vibrate with greater amplitude.
- C the lattice atoms vibrate with smaller amplitude.
- D the number of charge carriers per unit volume increases.

(Total for Question 7 = 1 mark)

8 Which of the following is a base SI unit?

- A ampere
- B coulomb
- C ohm
- D volt

(Total for Question 8 = 1 mark)



9 Which term may be defined as the number of waves passing a point in one second?

- A wave speed
- B wavelength
- C period
- D frequency

(Total for Question 9 = 1 mark)

10 The diagram shows a displacement–distance graph at an instant for two waves, X and Y, travelling to the right.

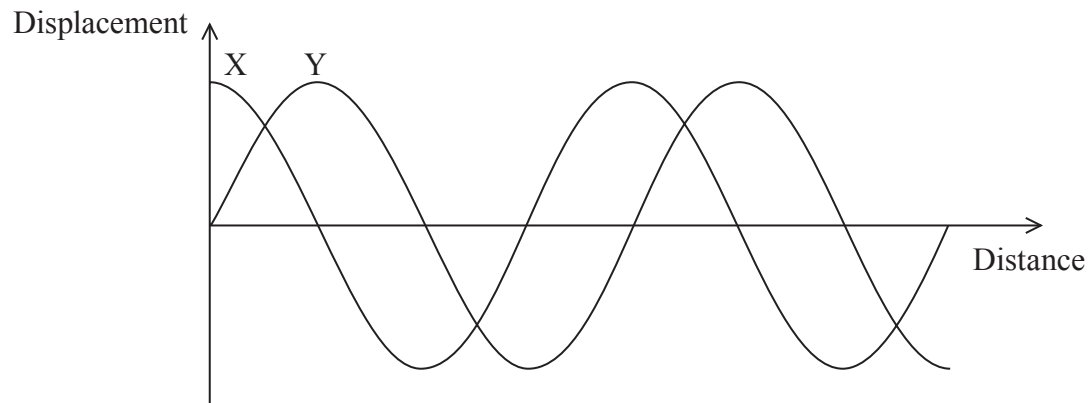

Which of the following statements correctly describes the phase relationship between the two waves?

- A X and Y are in antiphase
- B X and Y are in phase
- C X is $\pi/2$ radians ahead of Y
- D Y is $\pi/2$ radians ahead of X

(Total for Question 10 = 1 mark)

TOTAL FOR SECTION A = 10 MARKS



SECTION B

Answer ALL questions in the spaces provided.

11 Explain why an ammeter

- must be placed in series to measure current through a component
- must have a very low resistance.

(3)

.....

.....

.....

.....

.....

(Total for Question 11 = 3 marks)

12 When a cell of e.m.f. 1.5 V is connected across a resistance of 6.6 Ω the current is 0.21 A.

Calculate the internal resistance of the cell.

(3)

.....

.....

.....

.....

.....

.....

.....

Internal resistance =

(Total for Question 12 = 3 marks)



13 In the 17th century, Isaac Newton suggested that light was made up of very small particles which he called corpuscles.

Newton's theory was favoured in England throughout the 18th century because of his great reputation although scientists elsewhere applied the wave theory.

In 1801 Thomas Young demonstrated his double slit experiment. Monochromatic light from a narrow single slit was passed through a double slit and a pattern of light and dark bands was seen on a screen, as shown in the diagram.

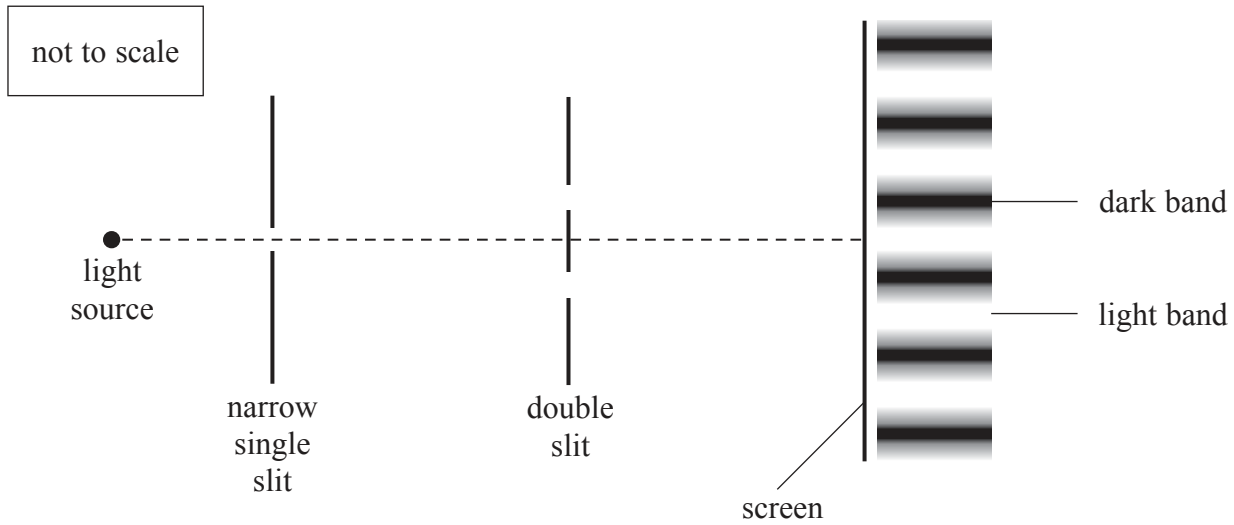

*(a) Explain how the light and dark bands are formed in the double slit experiment.

(4)

.....

.....

.....

.....

.....

.....

.....

.....

.....

.....



(b) The observation of light and dark bands with the double slit experiment depends on the light from the slits being coherent.

Explain why coherence is necessary to observe the light and dark bands.

(2)

.....

.....

.....

.....

.....

(c) State why Young's experiment disproved Newton's corpuscular theory.

(1)

.....

.....

(Total for Question 13 = 7 marks)



14 A rechargeable AA cell is labelled 2.0 Ah (ampere hours), 1.2 V.

(a) Show that Ah is a unit of charge.

(2)

.....

.....

.....

(b) When charging the cell, the current is 0.19 A and the potential difference is 1.5 V for 10 hours.

Calculate the electrical energy supplied while the cell is being charged.

(2)

.....

.....

.....

Electrical energy supplied =

(c) The maximum charge that can be delivered from a fully charged cell is 7200 C.

Calculate the maximum energy which could be transferred by the cell if the output potential difference remained constant at 1.2 V.

(2)

.....

.....

.....

Maximum energy =

(d) Calculate the efficiency of the charging process.

(2)

.....

.....

.....

Efficiency =

(Total for Question 14 = 8 marks)



BLANK PAGE



15 When light rays enter the Earth's atmosphere from space they undergo refraction. This can lead to a star appearing to be in a different position from its actual position.

(a) Explain what is meant by refraction and why it occurs for light entering the Earth's atmosphere.

(3)

.....

.....

.....

.....

.....

.....

(b) The diagram shows a ray of light from a star reaching the Earth's surface.

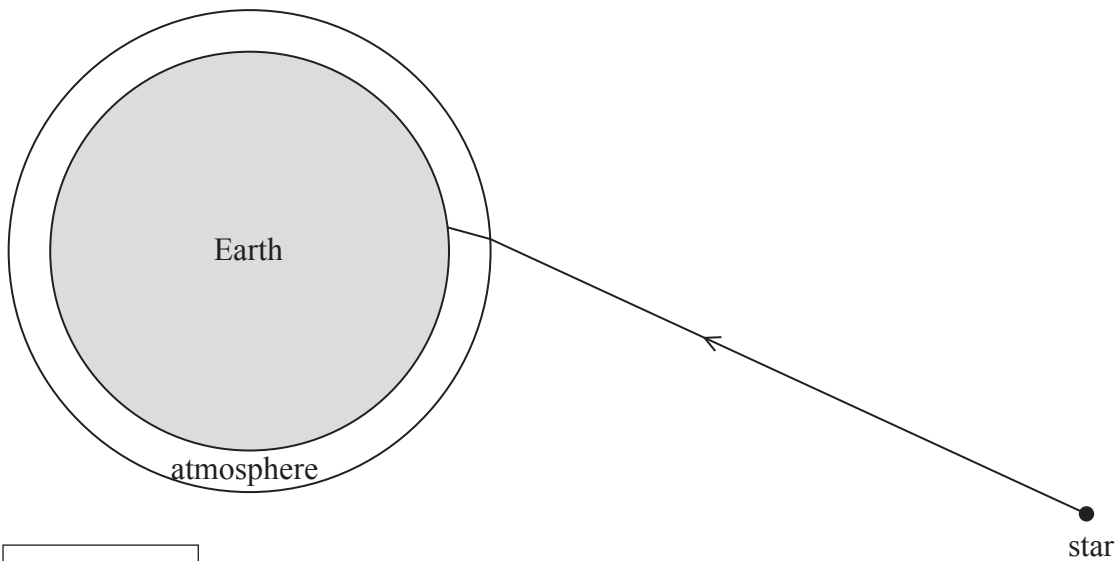

not to scale



The diagram shows in more detail the ray of light as it enters the atmosphere.

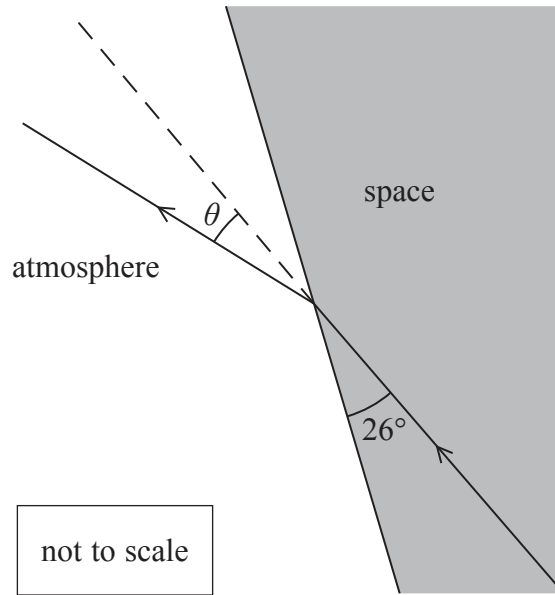

Calculate the change in direction θ of the ray.

refractive index of atmosphere = 1.001

(4)

.....

.....

.....

.....

.....

.....

.....

$\theta =$

(Total for Question 15 = 7 marks)



- 16 A student carried out a series of measurements to determine how the resistance of a wire varies with its length.

The student obtained the following results.

Wire length / cm	Current / A	Potential difference / V	Resistance / Ω
100	0.15	0.67	4.47
90	0.16	0.63	3.94
80	0.17	0.58	3.41
70	0.17	0.52	3.06
60	0.18	0.42	2.33
50	0.18	0.40	2.22
40	0.19	0.34	1.79
30	0.20	0.26	1.30
20	0.22	0.18	0.82
10	0.22	0.10	0.45

The student plotted the results on a graph.

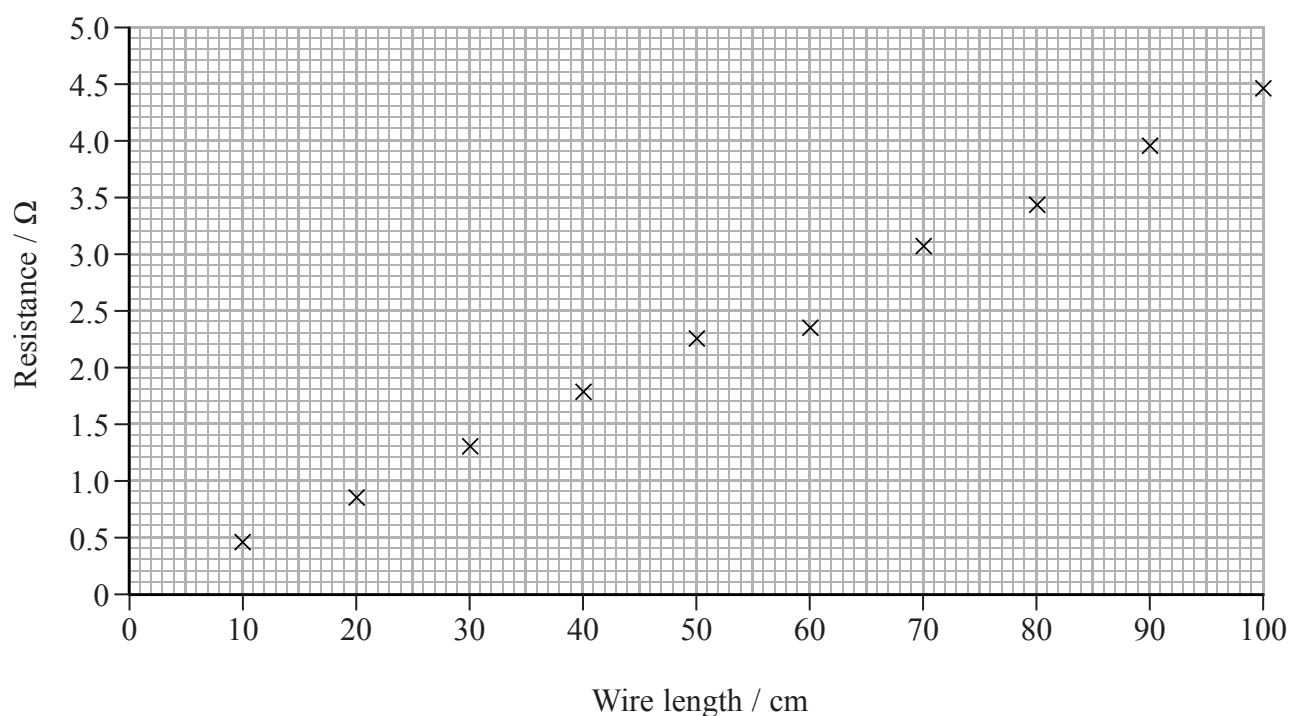

(a) Calculate the resistivity of the wire used.

cross-sectional area of wire = $1.06 \times 10^{-7} \text{ m}^2$

(4)

.....

.....

.....

.....

.....

.....

Resistivity =

(b) One precaution taken by the student was to keep the current small.

Explain why this precaution was necessary.

(2)

.....

.....

.....

(c) Explain **one** other precaution which should be taken by the student to ensure the accuracy of the results in the table.

(2)

.....

.....

.....

(Total for Question 16 = 8 marks)



(b) The diagram shows the spectral lines produced by a particular element when observed in a laboratory.

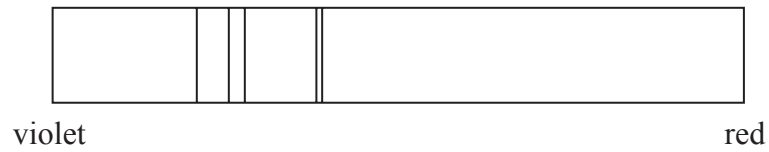

The diagram below shows the spectral lines obtained by analysing the light from a star. This shows the same pattern of lines, but in a different part of the spectrum.

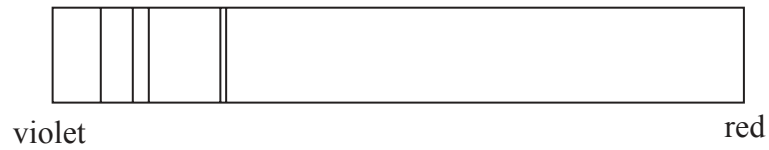

Name this effect and explain what may be deduced about the motion of this star relative to the Earth.

(3)

.....

.....

.....

.....

.....

.....

(c) Suggest what the phenomena in parts (a) and (b) imply about the nature of light.

(1)

.....

.....

(Total for Question 17 = 10 marks)



18 Dolphins use ultrasound when hunting prey. They emit short pulses of ultrasound, known as clicks, and detect the ultrasound reflected from their prey.

(a) Describe how ultrasound travels through water.

(2)

.....

.....

.....

.....

(b) Suggest why the dolphins emit a series of clicks rather than a continuous sound.

(1)

.....

.....

.....

.....

(c) When searching for prey the dolphins emit 16 clicks per second.

(i) Show that the time between clicks when searching for prey is about 0.06 s.

(1)

.....

.....

(ii) Calculate the maximum distance that can be determined by the dolphin when searching for prey.

speed of sound in seawater = 1530 m s^{-1}

(3)

.....

.....

.....

.....

.....

.....

.....

.....

Maximum distance =



(iii) The dolphin increases the number of clicks per second to 125 when near to capturing its prey.

Suggest why.

(1)

(d) Bats use ultrasound in air when hunting prey. The ultrasound frequency and the duration of the click is the same for both bats and dolphins.

Explain whether bats or dolphins would be able to locate their prey more precisely.

speed of sound in air = 330 m s^{-1}

(3)

(Total for Question 18 = 11 marks)



19 Phototubes are devices which make use of the photoelectric effect to detect light above a specific frequency.

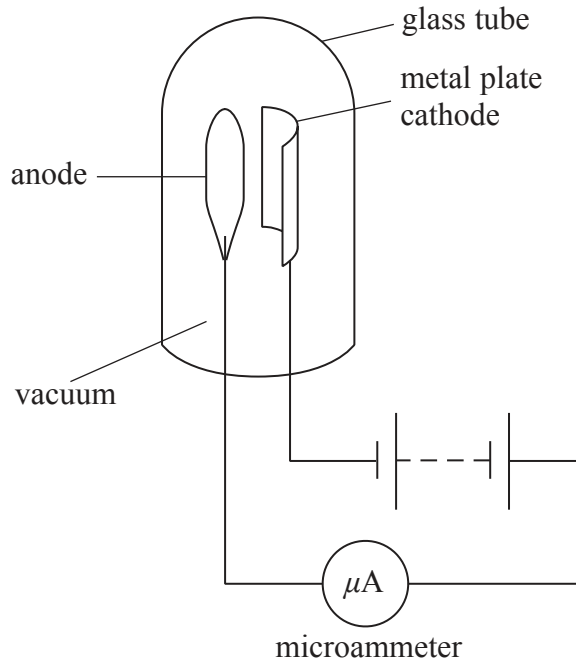

(a) Explain why

- no current flows when the phototube is in darkness
- current flows in the circuit when the phototube is illuminated by light above a specific frequency.

(5)

.....

.....

.....

.....

.....

.....

.....

.....

.....

.....

.....

.....

.....

.....

.....

.....

.....

.....

.....

.....

.....

.....

.....



(b) Make an appropriate calculation to explain why caesium is used as the cathode for visible light but zinc is not.

work function of zinc = 3.63 eV

work function of caesium = 2.14 eV

(4)

.....

.....

.....

.....

.....

.....

.....

.....

.....

(c) Before digital technology was used, the films used at the cinema had an optical soundtrack next to the picture frames.

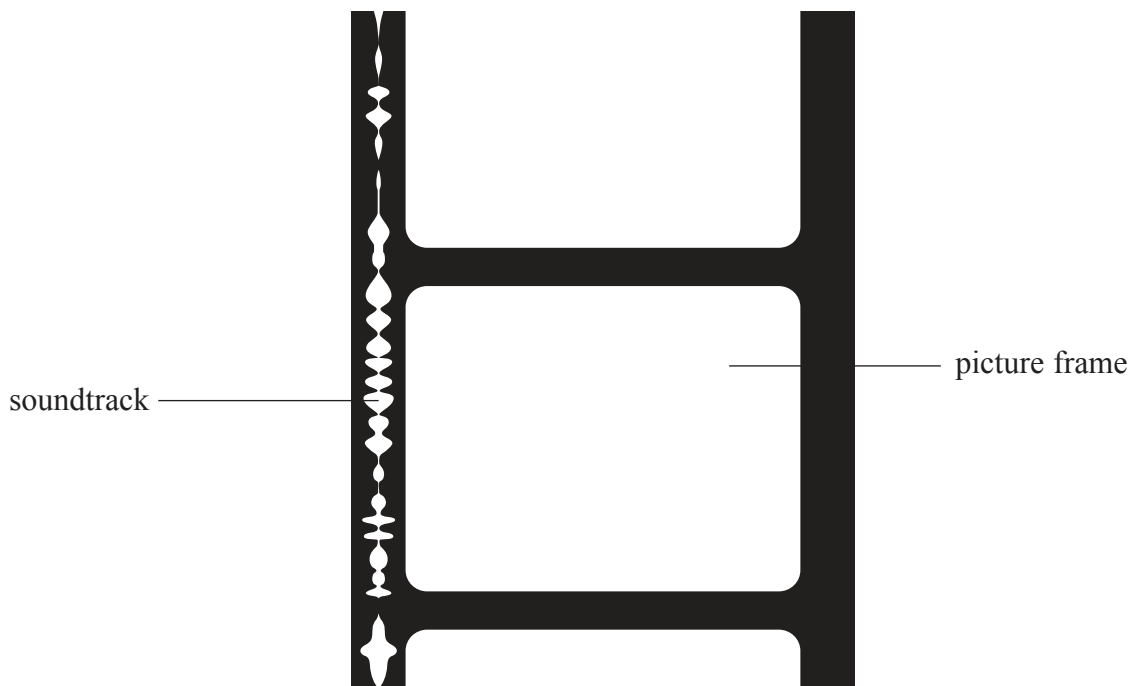

The film, including the soundtrack as shown, moves through a projector past a source of light. Light is detected by a phototube on the other side of the soundtrack. The changing current produced by the phototube circuit is converted to a sound signal with the same variation in amplitude and frequency as the original sound.



(i) State what is meant by amplitude.

(1)

.....

.....

(ii) Explain how the changing pattern of the soundtrack produces a changing current in the phototube circuit.

(3)

.....

.....

.....

.....

.....

.....

.....

.....

.....

.....

.....

(Total for Question 19 = 13 marks)

TOTAL FOR SECTION B = 70 MARKS

TOTAL FOR PAPER = 80 MARKS



List of data, formulae and relationships

Acceleration of free fall	$g = 9.81 \text{ m s}^{-2}$	(close to Earth's surface)
Electron charge	$e = -1.60 \times 10^{-19} \text{ C}$	
Electron mass	$m_e = 9.11 \times 10^{-31} \text{ kg}$	
Electronvolt	$1 \text{ eV} = 1.60 \times 10^{-19} \text{ J}$	
Gravitational field strength	$g = 9.81 \text{ N kg}^{-1}$	(close to Earth's surface)
Planck constant	$h = 6.63 \times 10^{-34} \text{ J s}$	
Speed of light in a vacuum	$c = 3.00 \times 10^8 \text{ m s}^{-1}$	

Unit 1

Mechanics

Kinematic equations of motion	$v = u + at$ $s = ut + \frac{1}{2}at^2$ $v^2 = u^2 + 2as$
Forces	$\Sigma F = ma$ $g = F/m$ $W = mg$
Work and energy	$\Delta W = F\Delta s$ $E_k = \frac{1}{2}mv^2$ $\Delta E_{\text{grav}} = mg\Delta h$

Materials

Stokes' law	$F = 6\pi\eta rv$
Hooke's law	$F = k\Delta x$
Density	$\rho = m/V$
Pressure	$p = F/A$
Young modulus	$E = \sigma/\epsilon$ where Stress $\sigma = F/A$ Strain $\epsilon = \Delta x/x$
Elastic strain energy	$E_{\text{el}} = \frac{1}{2}F\Delta x$



P 4 3 3 2 2 A 0 2 3 2 4

Unit 2

Waves

Wave speed	$v = f\lambda$
Refractive index	${}_1\mu_2 = \sin i / \sin r = v_1 / v_2$

Electricity

Potential difference	$V = W/Q$
----------------------	-----------

Resistance	$R = V/I$
------------	-----------

Electrical power, energy and efficiency	$P = VI$ $P = I^2R$ $P = V^2/R$ $W = VIt$
---	--

$$\% \text{ efficiency} = \frac{\text{useful energy output}}{\text{total energy input}} \times 100$$

$$\% \text{ efficiency} = \frac{\text{useful power output}}{\text{total power input}} \times 100$$

Resistivity	$R = \rho l/A$
-------------	----------------

Current	$I = \Delta Q / \Delta t$ $I = nqvA$
---------	---

Resistors in series	$R = R_1 + R_2 + R_3$
---------------------	-----------------------

Resistors in parallel	$\frac{1}{R} = \frac{1}{R_1} + \frac{1}{R_2} + \frac{1}{R_3}$
-----------------------	---

Quantum physics

Photon model	$E = hf$
--------------	----------

Einstein's photoelectric equation	$hf = \phi + \frac{1}{2}mv_{\max}^2$
-----------------------------------	--------------------------------------

